

INSTALLATION INSTRUCTIONS

Taymor

NORTHERN LIGHTS 06-3333AS
SINGLE HANDLE PRESSURE BALANCE
TUB & SHOWER FAUCET

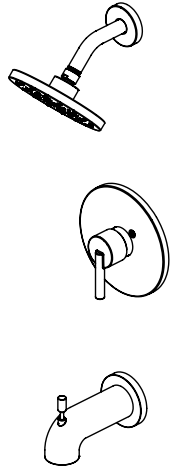

THIS FAUCET MEETS OR EXCEEDS THE FOLLOWING STANDARDS:
ASME A112.18.1/CSA B125.1 and ASSE 1016 (Type -P-).



THANK YOU FOR PURCHASING THIS TAYMOR PRODUCT. ALL TAYMOR PRODUCTS ARE CAREFULLY ENGINEERED AND FACTORY TESTED TO PROVIDE LONG TROUBLE-FREE USE UNDER NORMAL CONDITIONS



WARNING: READ ALL the instructions completely before beginning. **READ ALL** warnings, care, and maintenance information.

Taymor recommends calling a professional if you are uncertain about installing this product.

This product should be installed in accordance with all local and provincial plumbing and building codes.



CAUTION: Before completing installation, the installer must set the maximum water temperature setting of this valve to minimize the risks associated with scalding hazards according to **ASTM F444**.

NOTICE TO THE INSTALLER: CAUTION! As the installer of this valve, it is your responsibility to properly **INSTALL** and **ADJUST** this valve per the instructions given. This valve does not automatically adjust for inlet temperature changes, therefore, someone must make the necessary Rotational Limit Stop adjustments at the time of installation and further adjustments may be necessary due to seasonal water temperature change.

YOU MUST inform the owner/user of this requirement by following the instructions. If you or the owner/user are unsure how to properly make these adjustments, please refer to the instructions. After installation and adjustment, please fill in the blanks in the information box in the instructions. Retain the instructions for future reference.

NOTICE TO HOMEOWNERS! This device has been preset by _____ of _____ to ensure a safe maximum temperature. Any change in the setting may raise the discharge temperature above the limit considered safe, and lead to scalds. Date: _____

WARNING: This pressure balanced bath valve is designed to minimize the effects of outlet water temperature changes due to inlet pressure changes commonly caused by dishwashers, washing machines, toilets and the like. It may not provide protection from hot water burns when there is a failure of other temperature controlling devices elsewhere in the plumbing system, if the Rotational Limit Stop is not properly set, if the hot water temperature is changed after the Rotational Limit Stop is set, or if the water inlet temperature changes due to seasonal variations. The pressure balanced device does not control temperature, only pressure fluctuations. The limit stop does not control temperature variations, caused by inlet temperature variations.

Need Help? Please call our toll-free Customer Support line at
(WEST) 1-800-267-4774 (EAST) 1-800-387-7064 for additional assistance or service.

2 TURN OFF THE MAIN WATER SUPPLY

Locate water supply and shut off water supply valves. These are usually found near water meter.

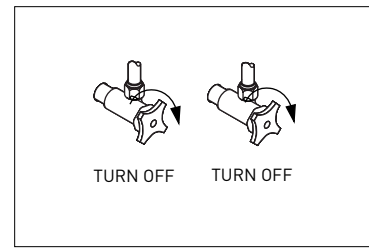

3 DETERMINE LOCATION OF THE VALVE, AND INSTALL THE SUPPORT FRAMING IN DESIRED LOCATION.



Using other distances may cause back pressure and result in water flowing from the showerhead and tub spout at the same time.

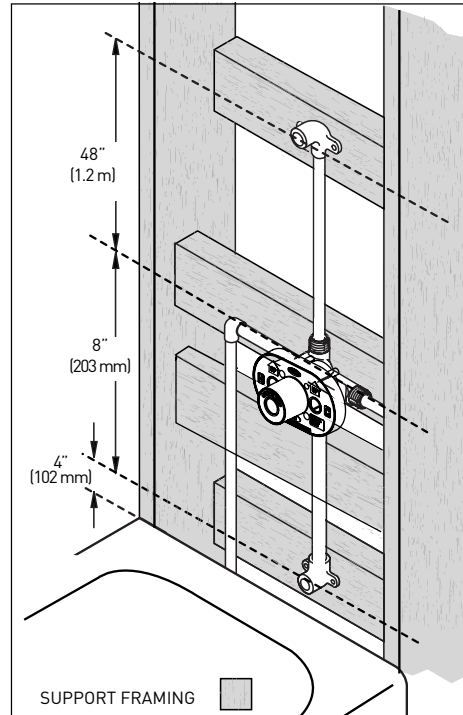

NOTE: ALLOW CLEARANCE BETWEEN THE CENTER OF THE SHOWER HOLE AND THE CEILING

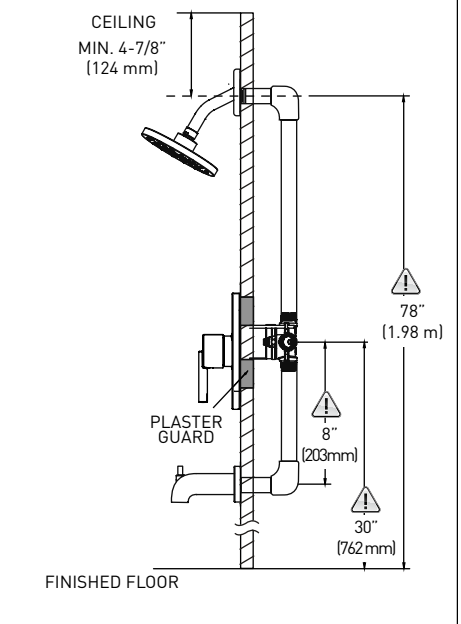

ROUGH-IN DEPTH

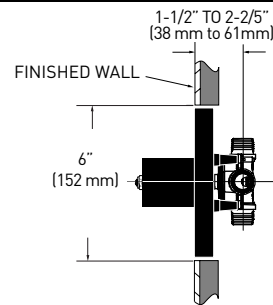

MAKE SURE THE SURFACE OF THE FINISHED WALL IS FLUSH WITH THE FRONT OF THE GUARD

THIN WALL INSTALLATION

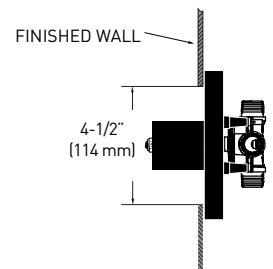

PLASTER GUARD MUST BE BEHIND THE WALL

3A FOR SHOWER (WITHOUT TUB SPOUT) INSTALLATION ONLY

IF YOU ARE NOT MAKING A SHOWER ONLY INSTALLATION SKIP STEP 3A, CONTINUE WITH STEP 4.

A) Determine location of the valve, and install the support framing in desired the location.

B) Plug valve **DOWN** outlet with pipe plug.

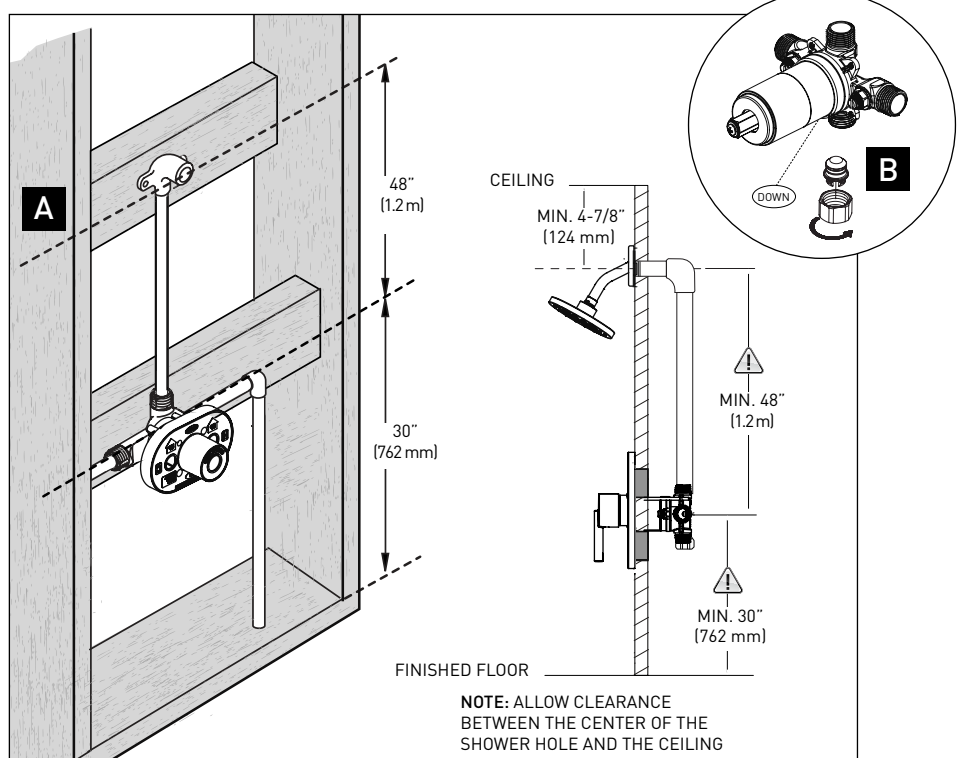

1 HAVE BASIC TOOLS READY

RECOMMENDED TOOLS:

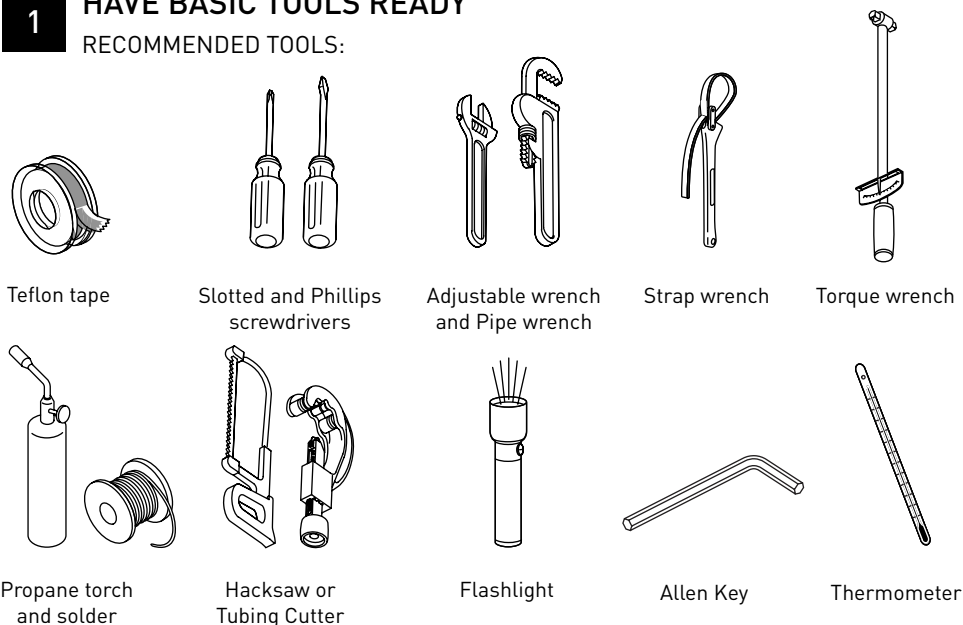

CUSTOMER SERVICE WEST 1-800-267-4774 | EAST 1-800-387-7064 | taymor.com

© REGISTERED TRADEMARK OF TAYMOR INDUSTRIES LTD. OCT. 2018

INSTALLATION INSTRUCTIONS

NORTHERN LIGHTS 06-3333AS
SINGLE HANDLE PRESSURE BALANCE
TUB & SHOWER FAUCET

Taymor

4 SECURE THE VALVE BODY TO FRAMING

Remove plaster guard: Unscrew the screws (1), and remove the plaster guard (2). Utilize integrated valve mounting holes to brace the valve properly. Screws can be accessed through the plaster guard.



Be sure to position the body correctly in the wall, with the markings **UP** facing upward.

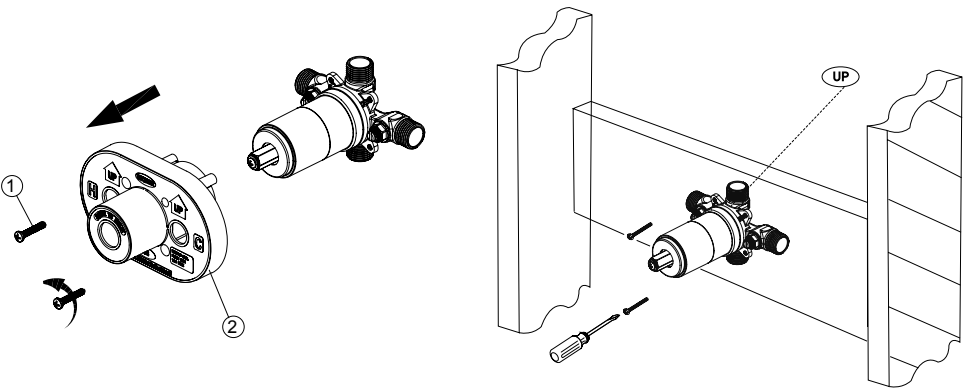

5 CONNECT WATER SUPPLY PIPING FOR SHOWER ONLY

Connect **UP** outlet to shower pipe

FOR THREAD CONNECTIONS

Valve body inlets and outlets are designed to accommodate 1/2" IPS threaded coupling connection. Wrap thread sealant tape* around the pipe threads in a clockwise direction as shown. Connect the hot and cold water supply lines (1*), the shower outlet pipe (2*) into the valve body (3) in a clockwise direction. Tighten the pipes to the valve body (3) with a pipe wrench*. Wrap thread sealant tape around the threads of the plug (4) and insert it into the bottom outlet (5). Connect the pipe elbows (6) to the end of the shower outlet pipe. **Note A:** Be sure to position the body (3) correctly in the wall with the markings "UP" facing upward. **Note B:** The hot water supply lines go into the "H" inlet, and the cold water supply lines go into the "C" inlet.

*Not included

APPLY PIPE TAPE ONTO THREADED ENDS

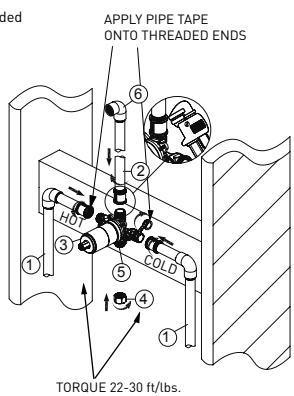

FOR SOLDERED COPPER CONNECTION

Prior to soldering any inlet or outlet connections, remove plaster guard, bonnet, o-ring, cartridge and valve stops. Failure to do so can result in water damage.

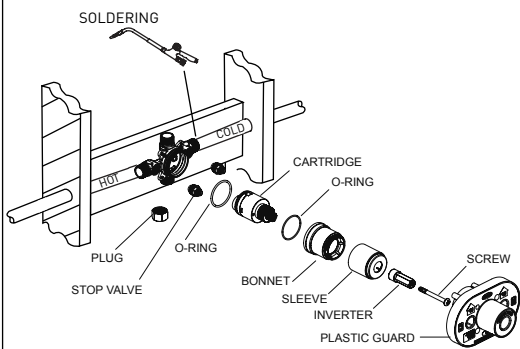

5A FOR BACK TO BACK OR REVERSE INSTALLATIONS ONLY (CONTINUED)

IF YOU ARE NOT MAKING A REVERSE OR BACK TO BACK INSTALLATION SKIP STEP 5A, CONTINUE WITH STEP 6.

REVERSE INSTALLATION

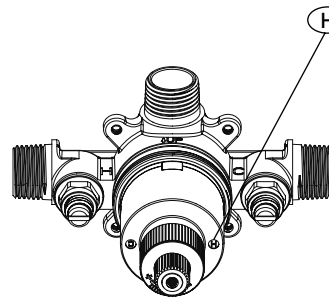

NORMAL INSTALLATION

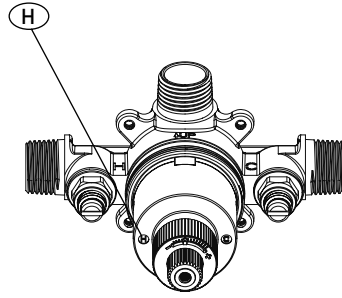

6 CONNECT WATER SUPPLY PIPING FOR BATH AND SHOWER

Connect **UP** outlet to shower pipe. Connect **DOWN** outlet to tub spout pipe. Connect pipe elbows to the ends of both pipes. Securely fasten to framing.



Use only 1/2" Iron or 1/2" (5/8" O.D.) copper pipe between valve and tub spout (No PEX)! Do not reduce the inner pipe diameter! Must be a straight drop 8" (203 mm) long with only one 90° elbow to the tub spout nipple.

FOR THREAD CONNECTIONS

Wrap thread sealant tape* around the pipe threads in a clockwise direction as shown. Connect the hot and cold water supply lines (1*), the shower outlet pipe (2*) and tub outlet pipe (3*) by threading them into the valve body (4) in a clockwise direction. Tighten the pipes to the valve body (4) with a pipe wrench*. Connect the pipe elbows (5*) to the end of the shower outlet and tub outlet pipes. **Note A:** Be sure to position the body (4) correctly in the wall with the markings "UP" facing upward. **Note B:** the hot water supply lines go into the "H" inlet, and the cold water supply lines go into the "C" inlet. **Note C:** Do not use PEX or CPVC between the valve and spout.

*Not included

APPLY PIPE TAPE ONTO THREADED ENDS

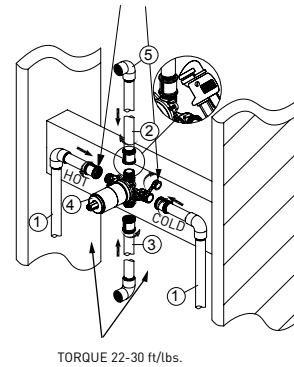

IMPORTANT

7 CHECK FOR LEAKS / FLUSH SYSTEM

Use two 1/2" iron pipe plugs on both shower outlet and tub spout outlet. Place handle on valve stem, and turn handle to full on mixed position. Turn on hot and cold water lines to full open position for one minute each. Check for leaks. Shut off water at faucet. Slowly remove pipe plugs from tub and shower outlets to relieve pressure. Turn on water allowing water to flow from tub spout until all foreign matter has cleared the line. Block one nipple to flush the debris out of the other nipple. Shut off water at faucet.



Check these areas for potential leaks!

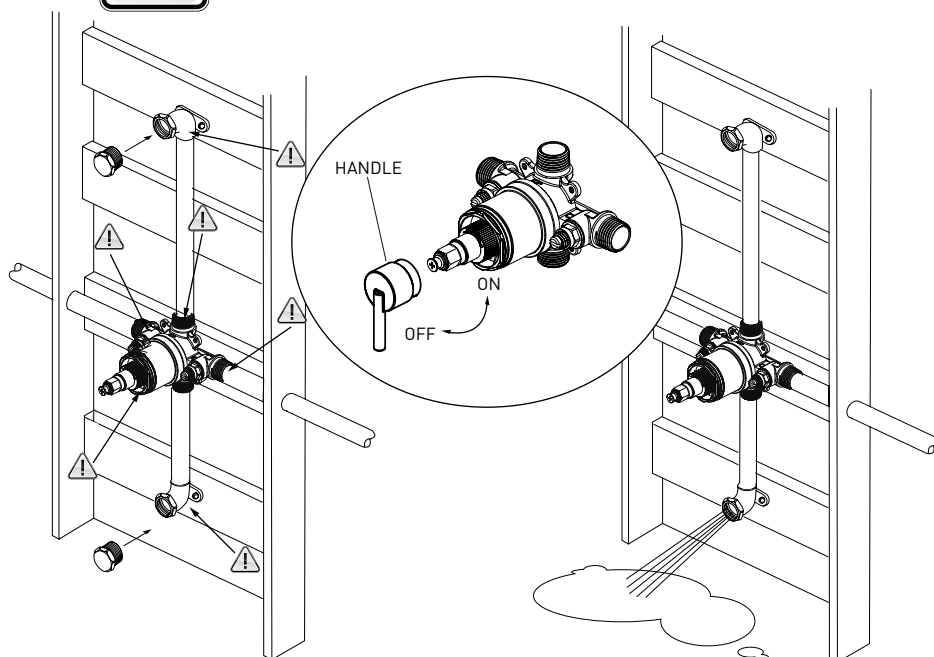

5A FOR BACK TO BACK OR REVERSE INSTALLATIONS ONLY

IF YOU ARE NOT MAKING A REVERSE OR BACK TO BACK INSTALLATION SKIP STEP 5A, CONTINUE WITH STEP 6.

If the hot and cold inlets are reversed (hot on right and cold on left), remove the screw (1), inverter(2), sleeve (3), and bonnet (4) from the valve body (5) with reversed supply connections. Rotate cartridge (6) 180° so "H" appears on the right. Install the cartridge making sure that the key is fully engaged with the slot in the valve body (5). Slide bonnet (4) over the cartridge (6) and thread onto the valve body (5). Hand tighten securely. Reassemble sleeve (3), inverter (2), with notch facing down) and screw (1).



Never install valve body upside down!

NORMAL INSTALLATION (CHANGES NOT REQUIRED)

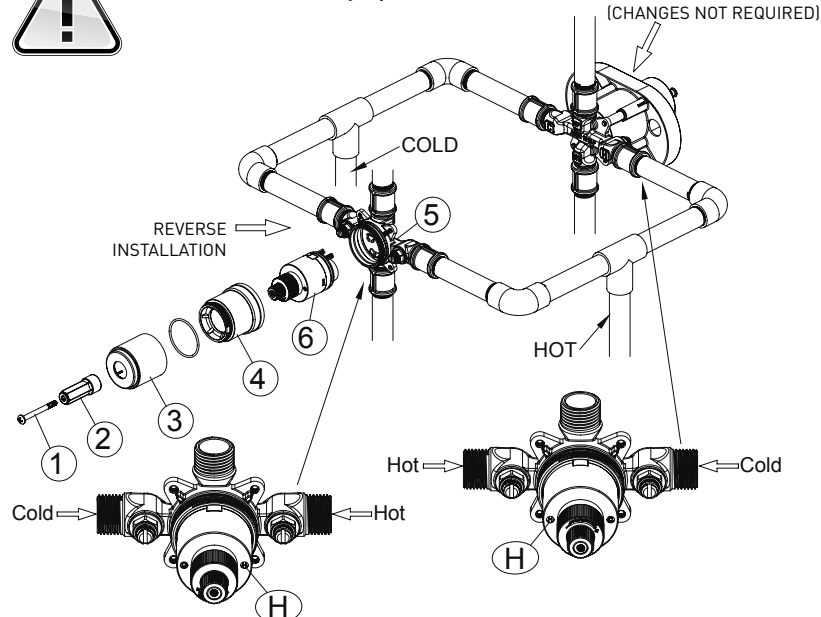

INSTALLATION INSTRUCTIONS



NORTHERN LIGHTS 06-3333AS
SINGLE HANDLE PRESSURE BALANCE
TUB & SHOWER FAUCET

8 ADJUSTING THE ROTATIONAL LIMIT STOP

LIMIT STOP RING IS FACTORY-SET TO PREVENT STEM FROM REACHING FULL HOT POSITION.

- A) Unscrew the sleeve (1) from the valve body (2). Unscrew the screw (3) from the inverter (4) and then remove the inverter (4) from the valve body (2).
- B) Remove the red limit stop ring (1) from the cartridge assembly (2) being careful to note the red limit stop's current position.
- C) Adjusting the desired maximum water temperature:
For a cooler water temperature, rotate the red limit stop ring (1) clockwise, then reinstall the red limit stop ring onto the cartridge assembly (2). For a hotter water temperature, rotate the red limit stop ring (1) counter-clockwise, then reinstall the red limit stop ring onto the cartridge assembly (2).
- D) A thermometer (not included) can be held under running water to aid in reaching the desired temperature. Water temperature for a comfortable bath or shower is typically between 32 °C - 38 °C (90 °F - 100 °F). Rotate stem clockwise to turn off.
- E) Place the inverter (1) onto the valve body (2) and rotate the inverter with the notch facing down, then secure with the screw (3). Screw the sleeve (4) onto the valve body (2). NOTE: Rotate the cartridge stem (5) clockwise to turn off the water supply before you install the handle.



Make sure water flowing from the valve at the hottest flow possible does not exceed 49 °C (120°F) or the maximum allowed by your local plumbing code.

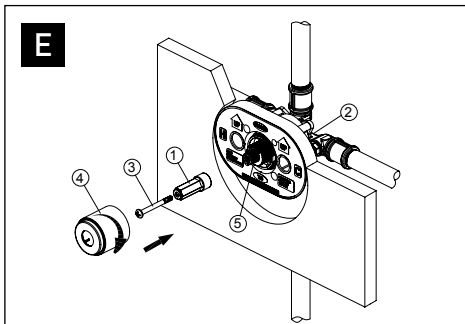
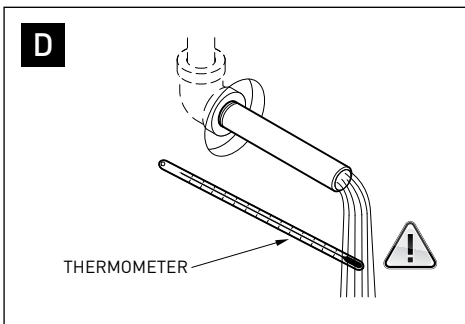
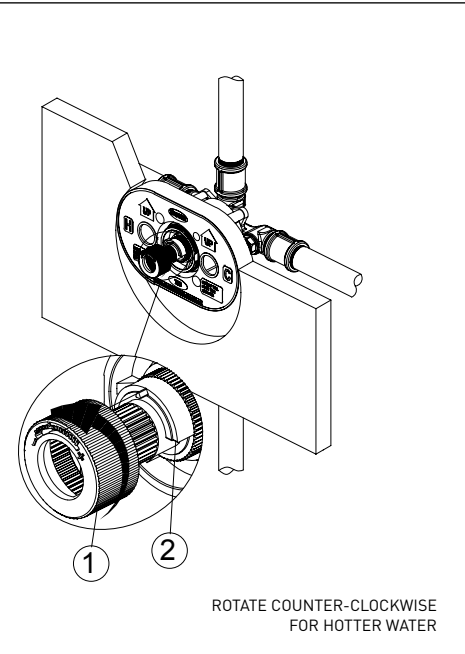
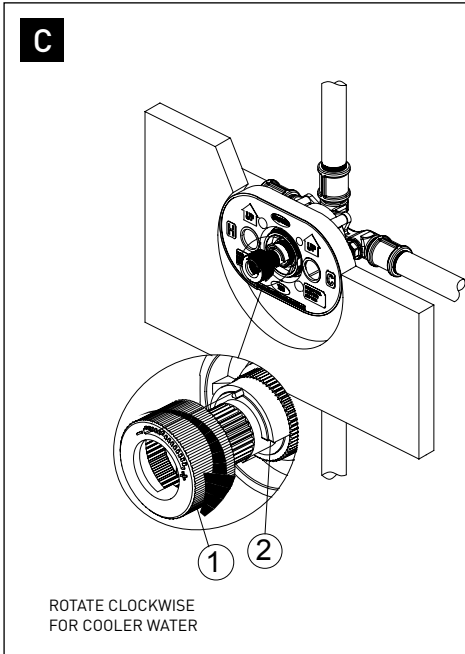
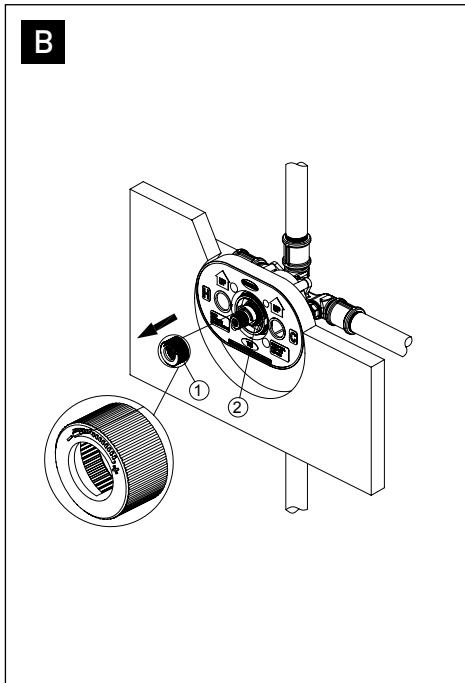
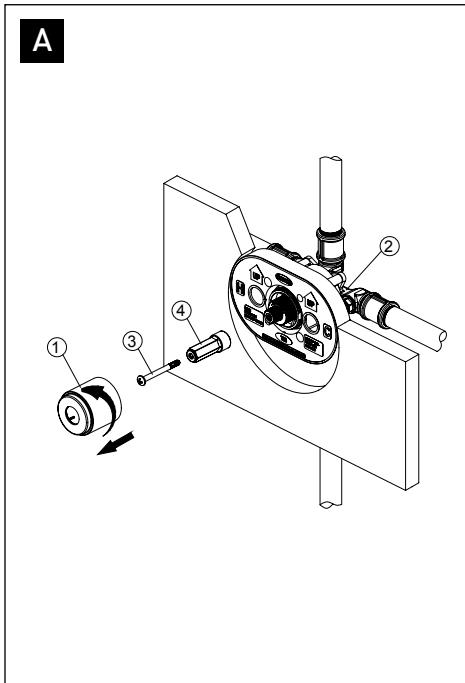

9 FINISHED WALL PREPARATION

- A) Replace plaster guard (1) into valve body (2) and secure with screws (3).
- B) Proceed to finish wall. Make appropriate holes to finished wall.

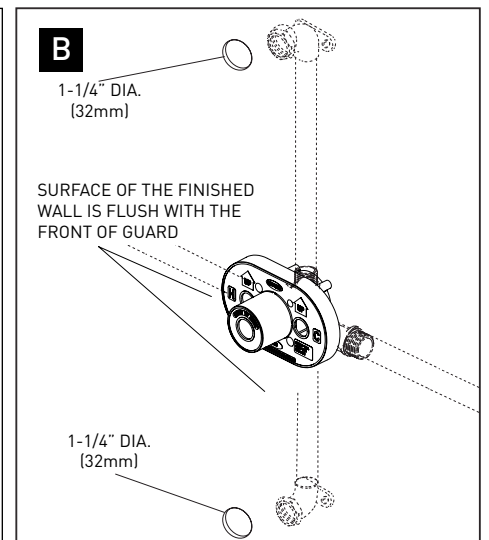
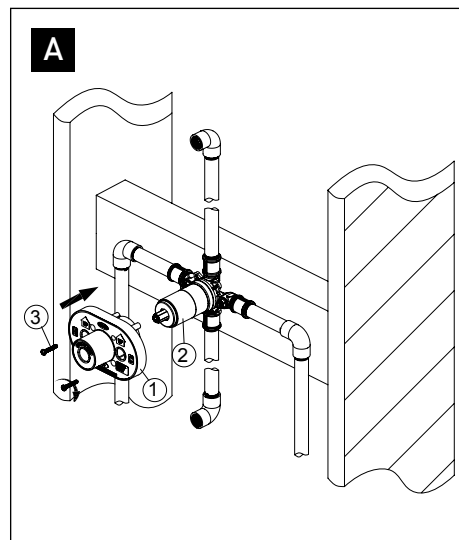

9A FOR THIN WALL INSTALLATION ONLY

IF YOU ARE NOT MAKING A THIN WALL INSTALLATION SKIP STEP 9A, CONTINUE WITH STEP 10.

For fiberglass, acrylic and other thin wall construction cut 4-1/2" (114mm) diameter hole which has the same centre with the valve location.

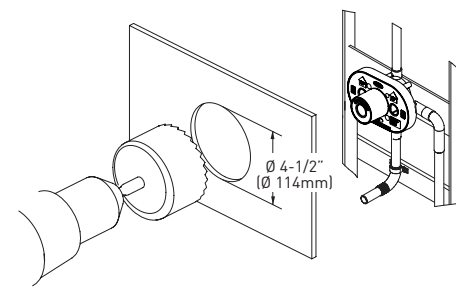

10 SPOUT INSTALLATION

- A) The stub-out pipe is to project 4-1/8" (105 mm) to 4-9/32" (109 mm) from the finished wall.
- B) Apply plumber's tape to pipe threads on stub-out pipe. Screw stub-out pipe into the elbow inside the wall and tighten with pipe wrench.

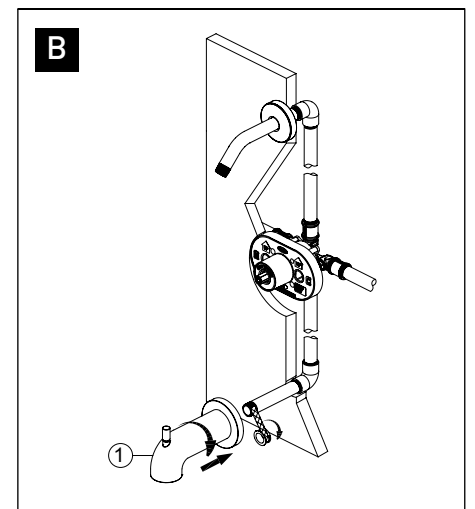
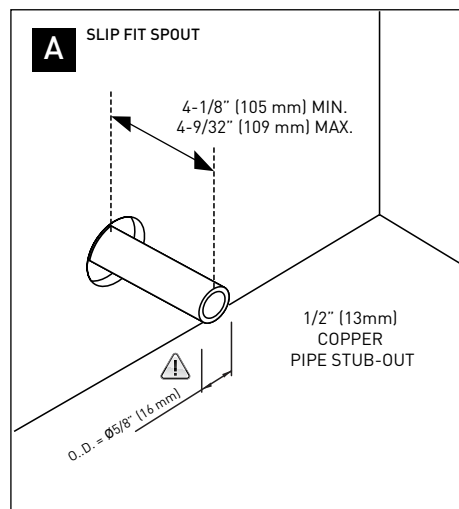

INSTALLATION INSTRUCTIONS



NORTHERN LIGHTS 06-3333AS
SINGLE HANDLE PRESSURE BALANCE
TUB & SHOWER FAUCET

11 SHOWER ARM INSTALLATION

- A) Apply plumber's tape to the end of the connector.
- B) Insert the wall end of the shower arm (2) through the shower flange.
- C) Apply plumber's putty or sealant to the shower flange. Finally slide shower head into shower arm (1).

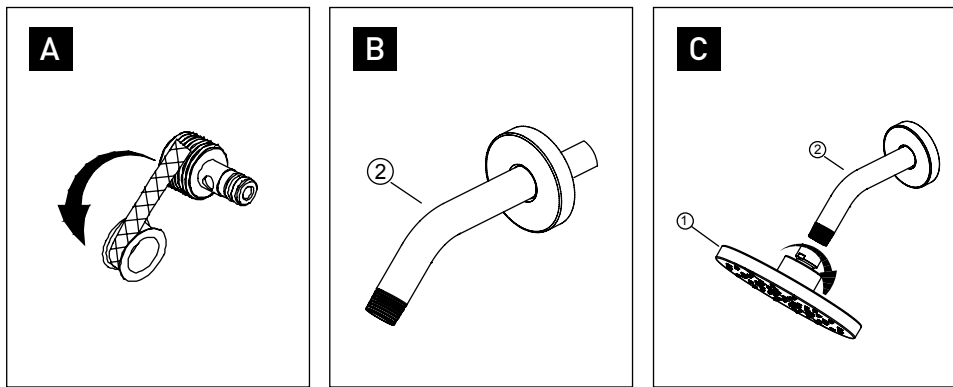

12 INSTALL ESCUTCHEON AND HANDLE ASSEMBLY ONTO VALVE BODY

Install the escutcheon (1) onto the valve body (2) using escutcheon screws (3). Place the handle (4) onto the valve body (2) and tighten the set screws (5) with the Hex wrench (Hex 2.5 mm, 6) provided.

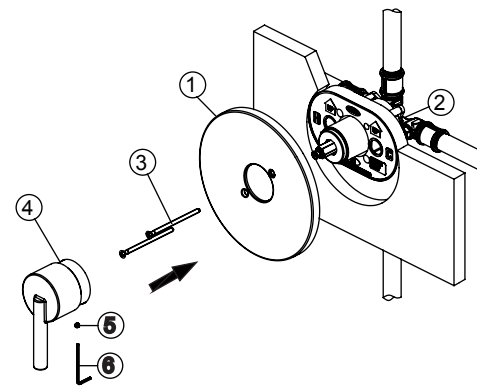

EXPLODED DIAGRAM FOR REFERENCE

MAINTENANCE Your new faucet is designed for years of trouble-free performance. Keep it looking new by cleaning it periodically with a soft cloth. Avoid abrasive cleaners, steel wool and harsh chemicals as these will dull the finish and void your warranty.

